

FORM ARCHITECTURE
ENGINEERING

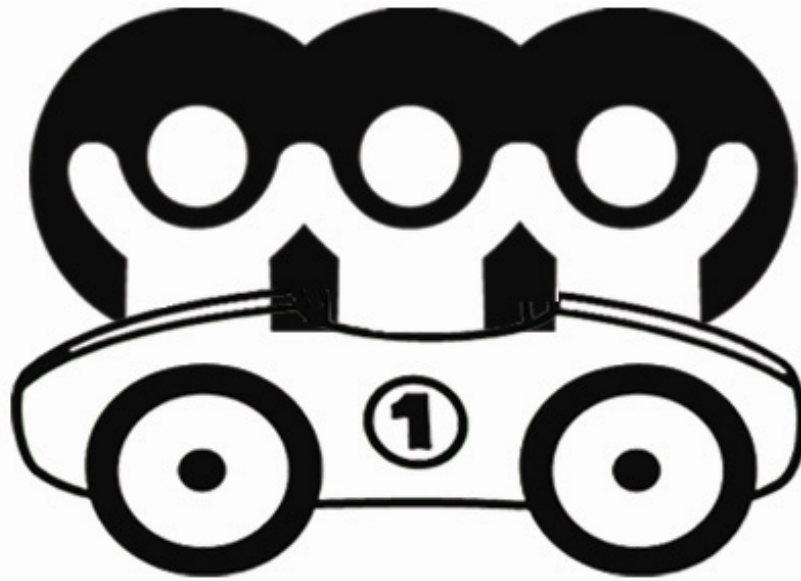

George Jeffrey
Children's Centre

 Soapbox Races 

Soapbox Builder's Manual

TABLE OF CONTENTS

	Page
REGISTRATION	1
BUILDING RULES AND REGULATIONS	2
MANDATORY CAR DIMENSIONS	3
HOW TO GET STARTED	4
COMPONENT DETAILS	5
Axles	5
Wheels	7
Brakes	7
Steering	10
Cable Clamps	11
Seat Belts	12
Roll Bar / Head Rest	13
Alignment of Rear Axle	14
Balancing	14
Body	14
TWO-PERSON CARS	15
MODIFIED CLASS	16
SAFETY AND SPECIFICATION CHECKLIST.....	17
Structural Safety	17
Driver Proficiency	17
INSPECTIONS	18
RACING RULES AND REGULATIONS	19
Race Marshaling / Set-Up	19
Multiple Drivers	19
Re-races	19
False Starts and Emergencies	19
Braking at Finish Line	20
Repairs	20
Questions and Concerns	20

REGISTRATION

- **Registration is on a first come basis and space is limited, so REGISTER EARLY.**

- **Registration alone does not guarantee that you will be allowed to race down the hill.**
 - *Car and driver together must pass a technical inspection.*

- **Minimum Age Requirement:**
 - *Drivers, age eight and up on race day, are eligible.*
 - *Drivers from the 'Modified Class' must be a minimum of 8 years*

- **Car numbers will be assigned once the registration has been received.**

- **Cars can ONLY be registered ONCE IN A CLASS, but may be registered in more than one class.**
 - *ie - Two drivers in the same age/class will have to share driving.*

- **Modified Cars are eligible to race ONLY in the Modified Class, and the Corporate 12 Class D.**

- **Driver changes, within 48 hours of the event, must receive prior approval of the organizers.**

BUILDING RULES AND REGULATIONS

- 1) This Derby is for 'home-built' racers. 'Kit Cars' will be permitted to race, as outlined later. *[See Modified Class]*
- 2) Mandatory Car Dimensions must be followed. See the 'MANDATORY CAR DIMENSIONS' section for specifics.
- 3) Cars must run on four wheels - two front and two rear. All four wheels must touch the ground at all times when racing.
- 4) The floorboard of the racer must be made of 5/8" (16mm) or 3/4" (19mm) plywood, or of materials that provide equivalent structural support. Particleboard is NOT acceptable. *[SEE 'Two-Person' Car Section for special requirements, in 'E' Class.]*
- 5) Feet must be foremost when driver is in racing position.
- 6) Seat belts are required. See the 'SEAT BELTS' section for specific placement and attachment requirements.
- 7) A properly fitting helmet must be worn. Motorcycle, football, or hockey helmets are acceptable. Full-face protection is strongly recommended.
- 8) Drivers should wear shoes and eye protection during competition, and may also be required to wear elbow and/or knee pads.
- 9) **Foot-operated brakes only.** NO bicycle caliper brakes. Brakes must be capable of stopping the car in a short straight line, with no damage to the road surface.
- 10) **Hand Brakes, by special exception only,** as per procedure outlined in #18 (below).
- 11) Steering must incorporate a steering wheel of some sort (circular, or similar design) fastened to a solid shaft. Steering wheel must not have any protrusions, such as with a T-bar style that could pose a hazard in a collision. If cable is used, it must be of the "marine/aircraft" type. Clothesline cable is NOT acceptable.
- 12) All body components will be of WOOD material. Fiberglass and/or sheet metal, etc will not be allowed in Classes A, B, or C (Corporate 10). The 'Modified Class' is less restrictive, but will be more carefully scrutinized and inspected.
- 13) A roll bar is optional, but recommended. See the 'ROLL BAR' section for specific placement and attachment requirements.
- 14) Axles must be 1/2" minimum solid or threaded rod or equivalent.
- 15) All major components must be attached with through bolts, not screws.
- 16) Each car must display its assigned number clearly on both sides of the car body.
- 17) No car shall display questionable advertising or sponsorship (ie something not appropriate for children to read or see).
- 18) Double or two-person cars, etc will require advanced inspection of plans before building starts. This vehicle type will be allowed only in special circumstances, through consensus of inspection committee. *[For further details, see 'Two-Person' Car Section.]*

MANDATORY CAR DIMENSIONS

A. Axle Length (front & rear)

Maximum	36" (91.5 cm)	From 'outside-to-outside' of wheels
Minimum	30" (75.0 cm)	See Note Below

B. Protrusion of Axle Beyond Wheel Hub

Maximum	1" (2.5 cm)
---------	-------------

C. Length Overall

Maximum 'Overall'	84" (213.4 cm)
Maximum	70" From 'nose to center' of rear axle (Figure B)

D. Wheelbase (front to back axle measurement)

Minimum	40" (101.6 cm)
---------	----------------

E. Ground Clearance

Minimum	3" (7.6 cm)
---------	-------------

F. Body Overhang (front and rear)

Maximum	12" (30.5 cm) <u>or</u>
Provide a minimum 3:12 slope for ramp clearance.	

G. Seat or Seat Pad Height (above the center of the axles)

Maximum	5" (12.7 cm)
Care must be taken to keep the center of gravity as low as possible.	

NOTE: All cars must meet the mandatory official dimensions or they will not be eligible to race. Modified/Experimental variations must receive prior approval.

Figure A

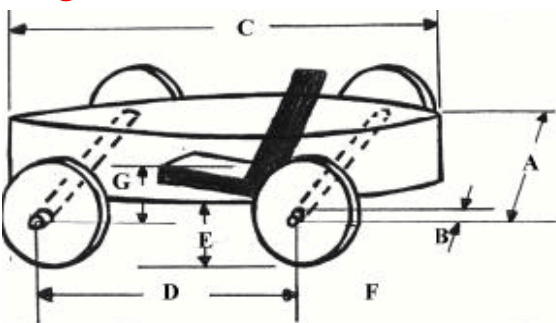
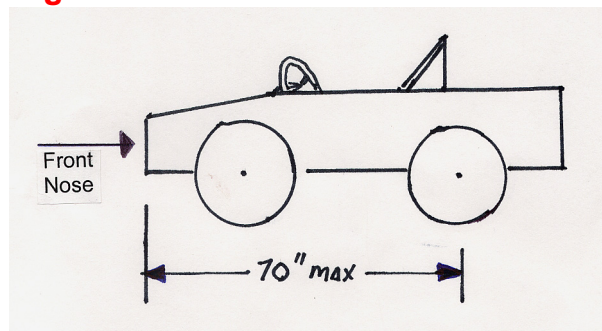

Figure B



HOW TO GET STARTED

Getting started properly is important and is a fairly simple step. You will not have to make all the decisions right at the beginning. **Please read through the complete manual before making any final commitments or cutting any materials.**

In most cases, you will start with a solid wood floorboard. A common material is a piece of 3/4" (19 mm) or 5/8" (16 mm) thick plywood. Decide roughly how long and wide the car is going to be.

Points to consider regarding size are:

- Size of driver (at present and in years to come).
- Transporting it to and from the race.
- You will need an area large enough to accommodate the completed car and remember – it also has to fit through the door later.
- Storage after the race.

The body width should be at least 12" (30 cm), and should not exceed the axle width of 36" (91.5 cm), as specified in the manual earlier. The length is primarily dictated by the height of the driver, and whether he/she is going to be in a sitting up or laying back position while driving. Remember the longer and wider the wheel base, the more stable the car will be.

On the floorboard, carefully draw a clear centerline. You will need this centerline many times during the construction.

To get some principal dimensions established, sit the driver on the floorboard, and use a couple of broomsticks to indicate the positions of the axles. Keep in mind the official specifications for wheelbase (minimum 40"; maximum 70" from nose to center of rear axle, as per **Figure B**). Try to distribute the weight evenly over all four wheels.

Mark the positions of axles, steering wheel, brake, brake pedal, seat, tip of the nose, and rear end. You will need to know which type of brake you want to use, as some may be positioned in a variety of locations, while others cannot. The more common brake designs include a vertical plunger, horizontal hockey stick or drop arm. Allow room (at least 6" or 15 cm) in front of the feet for brake pedal movement. Also keep in mind the way you wish to finish the front end of the racer. Remember to leave room if a solid bulkhead is used at the very front to protect the driver in the event of a collision. Also, the feet will stick up a fair distance from the floor, and the eyes of the driver should be a few inches above the toes, so the driver can see the road. The driver should be able to see the road clearly. It would be an asset if the front wheels were visible from the driver's position.

At this point, it is also a good idea to determine the shape of the racer as seen from above, the side and the ends. Is it going to be an elongated oval, a teardrop shape, or a rectangular wedge? With consideration being given to the structural design, body type and safety, you can now outline the shape of the floorboard symmetrically around the centerline and start cutting.

Next, decide where and how to anchor the roll bar (if used), so that it is an integral part of the main structure of the racer; for example the floor board and possibly also the main structures above the floorboard. From here your next steps greatly depend on your design. In some cases, the brake and steering components are easier to install before the frame or body. In others, the frame or body form the support structure for these components and must be installed simultaneously.

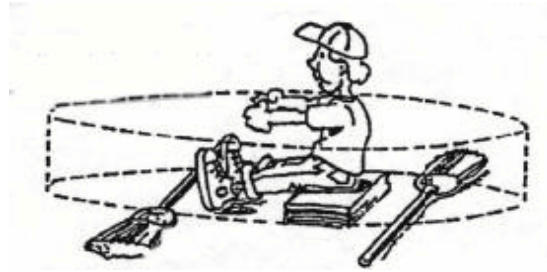

COMPONENT DETAILS

Axles:

The wheels must attach to a 1/2" minimum diameter axle rod or equivalent. This can be a threaded "Ready-Rod", which is simple because lock nuts can be used to position the wheel, as opposed to cotter pins. A lock nut does not require a hole to be drilled in the rod for a cotter pin; but "Lock-Tite" or similar method must be used to hold the nut in place. Since the rod may not be strong enough by itself, a wood axle-tree or other equivalent support for the axle may be required. (See diagrams)

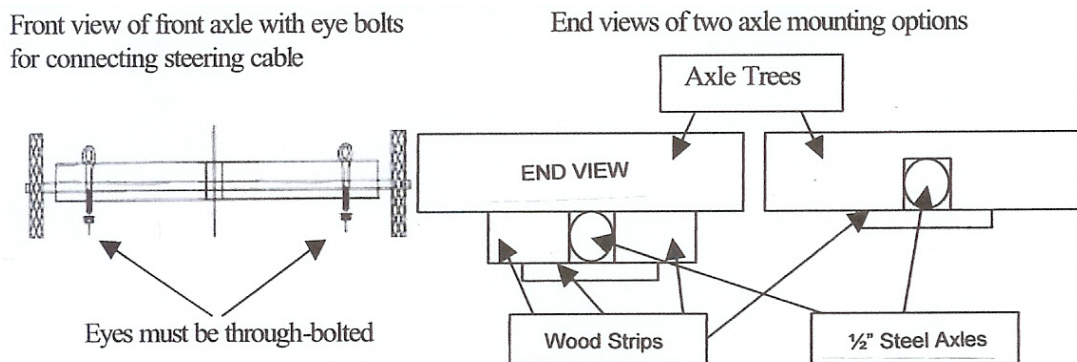

Properly installed U-Bolts are optional

Axles: (cont'd)

- The axle rod is supported by a 2" x 4" piece of wood (tree).
- Wood strips hold the rod in place on the main 2" x 4" tree. A routed channel can eliminate two strips. The front axle pivot is a loose fitting bolt holding the axle-tree to the floorboard (locking the nut is required to prevent it from loosening off). The pivot should be in front of the axle for stability.
- Sturdy eyebolts that are completely closed (**Figure C**), backed with locking nuts and washers, can be used to attach the steering cable to the axle-tree.
- The rear axle-tree can be bolted directly to the frame or floorboard.
- Mount the axles no more than 12" from the front and rear of the car or as defined in the **'MANDATORY CAR DIMENSIONS'** section.

Figure C

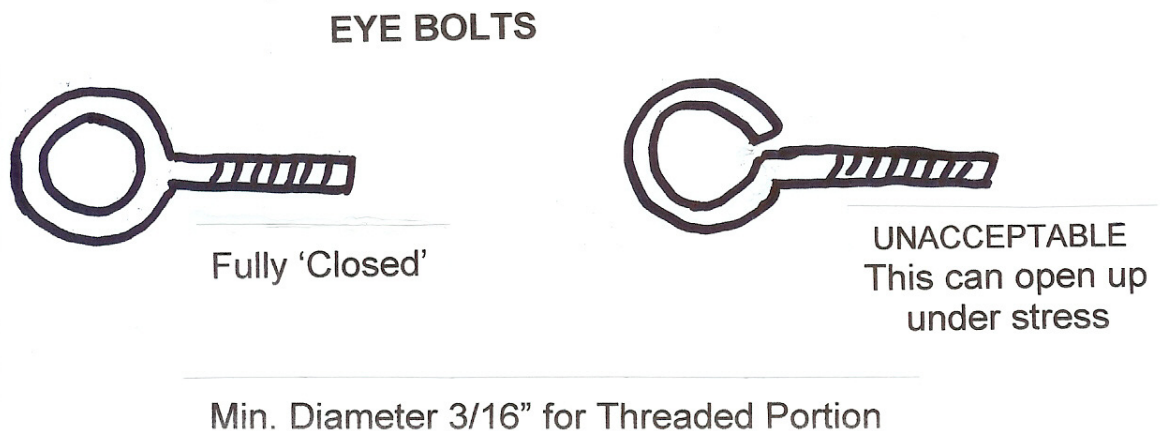

Wheels:

For Classes A, B & C: Maximum 10" diameter, solid disc metal, solid rubber. **NO** pneumatic tires. **NO** spoked centers. Shaved tires **must** have a minimum of half the tread width remaining.

For Classes D & M: Maximum 12" diameter, solid double disc metal, solid rubber. **NO** pneumatic tires. **NO** spoked centers. Approved (stamped) soap box composite wheels are acceptable.

Brakes:

There are several kinds of safe and reliable brakes. Some design features to consider are:

- Cost
- Ease of Construction
- Choice of Mounting Location Options
- Braking Effectiveness
- Skid Control
- Tire Wear
- Use of 1/8" aircraft cable (minimum) on **all** brake systems

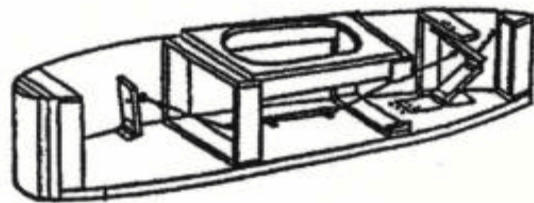

Hockey Stick Brake *(not as effective, as other types)*

The hockey stick brake uses a piece of strong hardwood **with rubber pads** (see diagram) parallel to the rear axle that is pulled up against both rear wheels by a cable. A spring pulls the bar off the wheels when the cable is released. It is quite simple and inexpensive to build.

MAKE SURE THAT THE STICK IS MOUNTED UNDER THE FLOORBOARD IF IT IS BEHIND THE AXLE, AND ABOVE THE FLOORBOARD IF IT IS IN FRONT OF THE AXLE. (Figure E)

In these positions, the rotation of the wheels will force the stick against the floorboard, providing support. Tires wear somewhat as the brake is applied and flat spotting can occur if the brake is applied too hard. The maximum braking power available from this brake is dependent on the weight of the car on the rear axle.

Figure D

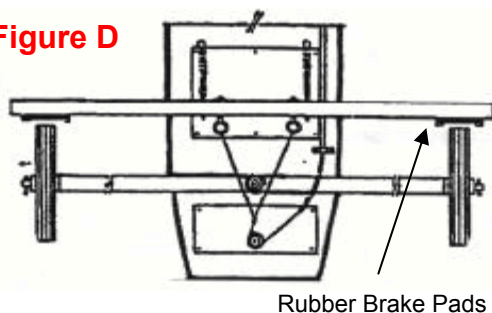
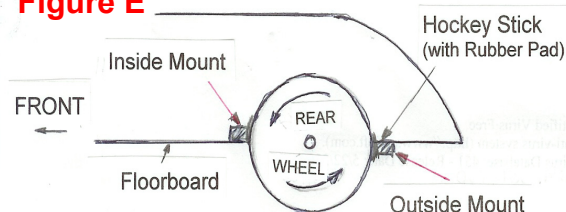

Figure E



Drop Arm Brake

The drop arm brake incorporates a hinged arm with a brake pad on one end that drags on the road surface. It is a popular design among serious racers because it can be designed to remain flush with the underside of the floorboard until the finish line, thus minimizing wind resistance. When the scissor or cam method is used to apply the brake, substantial mechanical advantages can be obtained providing high pressure with minimal pedal movement. The main hardware items needed to make the scissor brake are four large butt hinges. A cam system (not shown) made basically from plywood and one butt hinge can also be used to activate a drop arm brake. With a little geometry know-how, either is fairly easy to construct. This brake does not wear-on or flat spot the tires. Positioning it as far as possible ahead of the rear axle is best.

Figure F

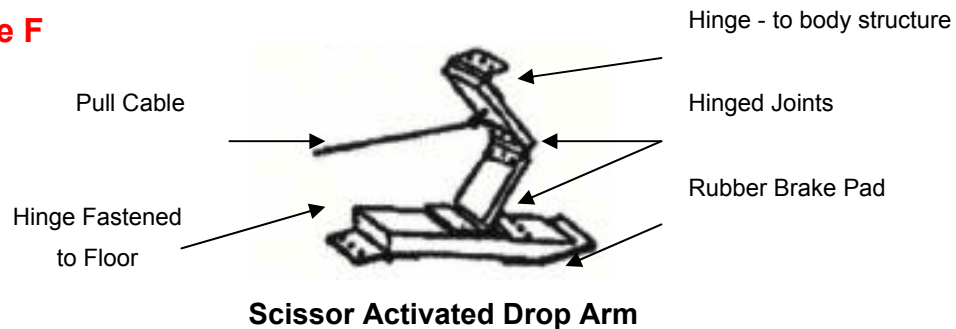

Plunger Brake *(most effective)*

The plunger brake is a brake that can be easily mounted in the back or middle of the car. It consists of a brake pad that is pushed vertically down onto the road surface. Some welding is usually required to build this system. Somewhat surprisingly, the best place for a plunger (or most ground contact type brakes) is slightly in front of the center of gravity of the car. The car's inertia during braking shifts the car's weight forward, applying weight from all four wheels equally. This provides more available friction and still allows good steering control.

Figure G

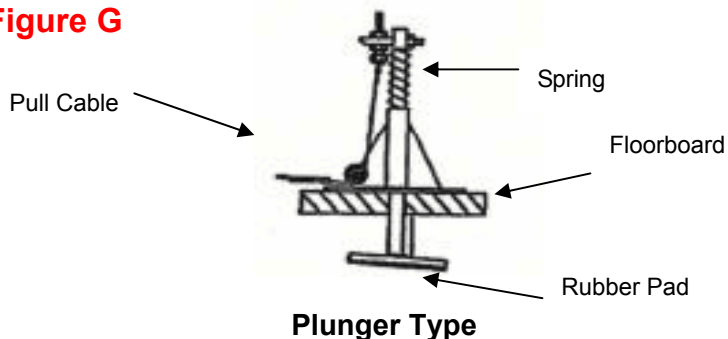

Brake Pads:

Automobile Tire Tread:

This is by far the best and only material recommended for ground contact brake pads.

The tread needs to be deep so that bolt heads can be tightened down deep between the tread. Most tire shops will let you pick through their discarded tires for free. Very often you will find rejects or damaged tires that have almost new tread on them. Nylon or Kevlar belted tires are harder to find than steel belted ones, but are easier to cut and do not leave prickly edges when cut. A hacksaw or scroll (jig) saw with a metal cutting blade works on the tread, or a hand grinder with a thin cutting disc. Mount the tire solidly and keep the saw kerf open. Tin snips or a sharp knife will work on the sidewalls. Again, keep the kerf open.

Brake pads must be attached to a backing material with through bolts and flat washers. The bolt heads must be sunk well below the contact surface so there is no chance of them ever coming in contact with the road.

Design your brake for the worst-case scenario, keeping in mind that the road may be wet or slippery making braking much more difficult.

The braking must be symmetrical with respect to the car. The car must be balanced from side-to-side and in the case of a hockey stick brake make sure pressure is applied evenly to both wheels.

Brake pads that drag on the ground must be able to extend 1" below the road surface to compensate for any road surface irregularities, such as ruts, etc.

Remember: Foot-operated brakes. Hand brakes by special permission **only** (see page 2).

**Bicycle Caliper Brakes
are NOT allowed.**

Steering:

- Use 1/8" (minimum) diameter aircraft cable, or better.
- Use 'closed' eye bolts (See **Figure C**); minimum size 3/16" diameter.

The steering mechanism is one of the most interesting aspects of the car to design and build.

The simplest steering system consists of a cable that is wrapped around a steering column. The cable passes through closed pulleys and is attached near the ends of the front axle. The steering column may be vertical, horizontal, or for that matter at any angle.

The cable is securely attached to the steering column or drum to prevent slippage and is tightened with turnbuckles. **Make sure the cable passes through and is wrapped around the steering column in the proper direction to prevent backward steering.** (See diagrams below for some examples.)

The steering wheel should be large enough to allow a secure grip, and have no sharp

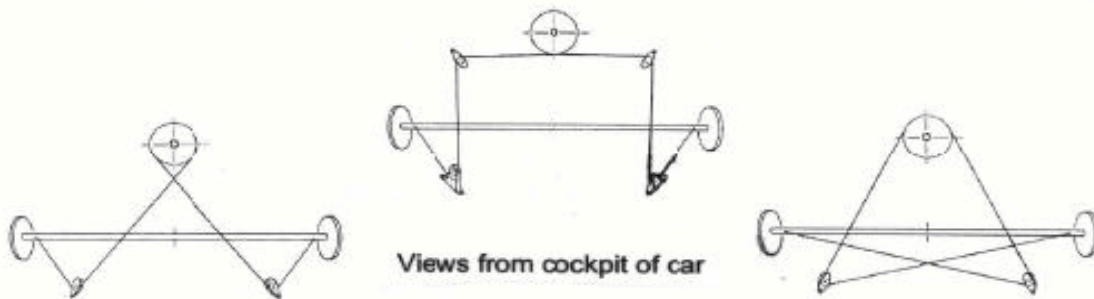

points or edges in any position (Figure H). The sensitivity of the steering should be neither "too quick", nor "too slow". **There should be minimal "play"**. The turning radius of the car can be relatively large since the racecourse will have very smooth curves, if any. Should the car get off course, however, it is important that corrections can be made. A minimum turning radius of 30 feet (10m) is adequate. **Stop blocks are mandatory** and must be secured extremely well. They must prevent the axle from turning the steering wheel excessively, if one wheel hits an object.

Figure H

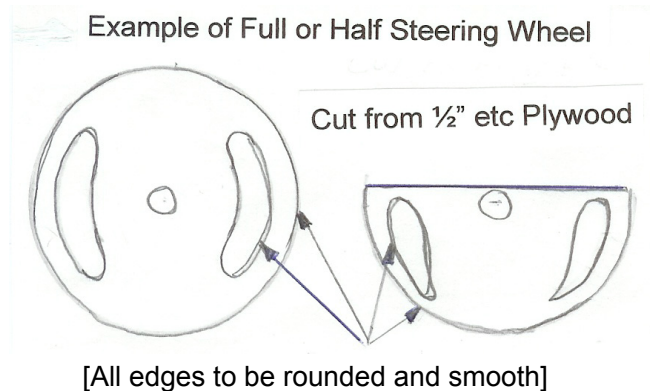

Cable Clamps:

'Saddle' type clamps are the ones with a 'U' shaped bolt that fits into two holes in a base piece called a 'saddle'. The 'U' bolt is tightened with two nuts clamping the cable between the 'U' bolt and the 'saddle'. These clamps are convenient, in that they can be reused without cutting the cable; however, the drawbacks are that the correct size (3/32") is hard to find, the 1/8" ones are only 45% as strong as crimps, and the nuts tend to loosen off as the cable settles over time.

The tricky part with the 'saddle' clamp is, knowing the correct way to put it on. The reminder is, "NEVER SADDLE A DEAD HORSE".

The 'DEAD' end of the cable is the end that is exposed (and pokes you) if you do not tape over it when you are done.

The 'SADDLE' is the part of the clamp with the holes in it. When you put the first clamp on (about an inch from the 'DEAD' end), make sure that the 'DEAD' end of the cable is under the 'U' bolt side of the clamp and not the 'SADDLE'. Tighten the nuts evenly. The second clamp must go between the first clamp and the object you are attaching the cable to. The space between the two clamps should be 6 times the diameter of the cable. Remember, the nuts on the clamp must be locked and checked regularly.

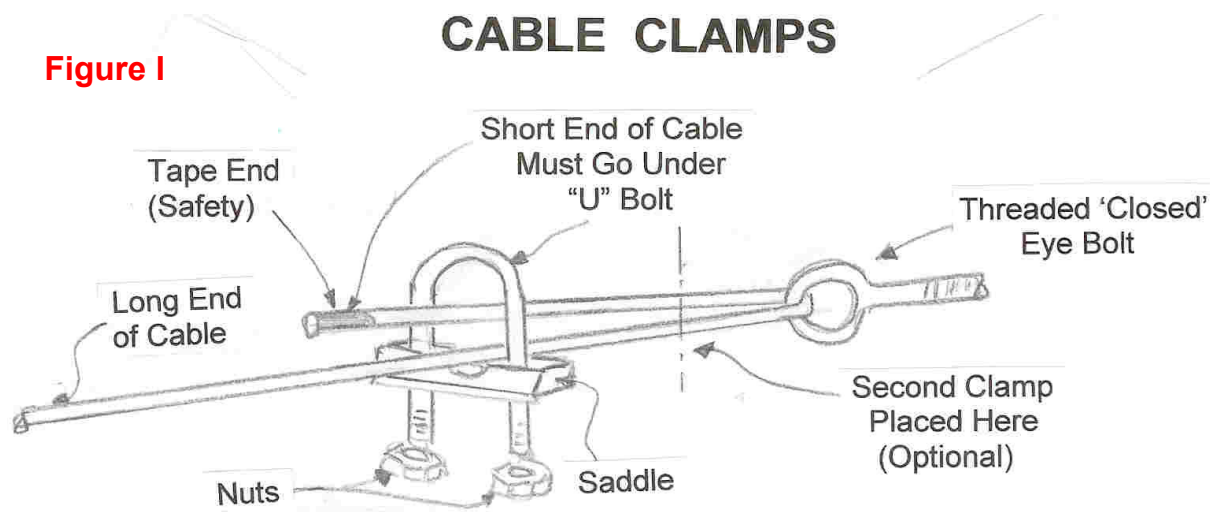

When turnbuckles are used for tightening the cables, they must be restricted from loosening themselves off. (Use either lock-nuts, or tie-wire.)

For the mechanically inclined, direct linkage steering is another option that can be used on either a straight axle or on independent swivel type systems.

Seat Belts:

'Lap Belt' is required **at minimum**. If ONLY a 'Lap Belt' is used, full-face protection is required. 'Lay Back' style requires a crotch belt, as well.

Seat belts have two main functions. They need to hold the driver in the car in the event of a roll over and they need to restrict the driver from hitting the steering wheel or dash of the car when involved in a frontal collision.

In a conventional lap/shoulder belt system, the lap belt holds the driver in the seat, while the shoulder strap holds the driver's upper body from moving forward. This is the most widely used system that meets the minimum requirements in our derby. It is simple to acquire and install. Some auto racing and aviation type restraint systems are obviously more effective, but may be difficult to come by or very expensive.

Another less popular system is the three point, two shoulder belt, system. It uses a lower attachment point below the crotch. Depending on the style and position of the seat, a wedge as described below may be required.

Incorporating shoulder belts in 'Lean Forward' style cars has always been a challenge because if the shoulder belt is tight, the driver can no longer lean forward. We have found, however, that a shoulder strap can still be installed effectively in these cars. Because the intent of the shoulder strap is to prevent forward movement, it will still be effective, as long as it is tight when the driver is in the lean forward position and does not allow the upper body or head to come in contact with the steering wheel or dash of the car. **The belt also needs to be installed so that it cannot fall out of position (off the shoulder) while driving.** Special attention must be made in the roll bar design, so that it provides protection even when the driver is sitting upright with the shoulder strap loose.

In a 'Lay Back' style car, it is hard to prevent the driver from sliding forward when involved in a frontal collision. In this case, at least one of the following things is required.

1. A wedge can be installed in front of the driver's buttocks. The wedge should be as steep and high as possible, without being too uncomfortable. The seat should resemble a chair leaned back with a shortened seat pad. The front edge of the seat pad can be scalloped to allow the legs to straighten when braking. The lap belt should be anchored as close as possible to where the seat and the back of the chair meet.
2. Leg straps similar to those on climbing or fall arrest harnesses can be used, in addition to the lap and shoulder belts.

All seat belts must be securely attached to the floorboard, frame member or roll bar with through bolts.

Roll Bar / Head Rest:

The safety requirement here does not necessarily call for a metal tube shaped in an arch, but essentially a superstructure extending some inches above and to the sides of the driver's head and back. It should be made from solid materials and fastened securely to the floorboard and/or frame.

The best place for the roll bar is slightly ahead of the driver's face. This position allows it to deflect on-coming objects more safely. The roll bar must be positioned so that the driver's helmet is not able to reach imaginary lines extending from the top of the roll bar to the nose of the car and from the top of the roll bar to the rear of the car. (See diagram)

Roll bars must also extend on both sides of the driver's head. For 'Lean Forward' style cars, the roll bar height is determined when the driver is sitting upright.

It is very important to provide protection against potential whiplash, by providing an adequate headrest for the driver.

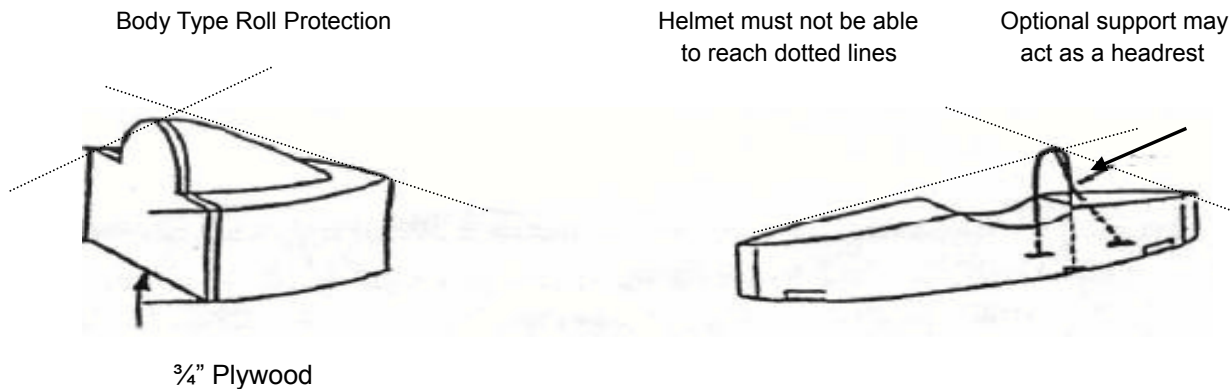

Alignment of Rear Axle:

First, check that the exact center of the rear axle is located exactly over the centerline on the floorboard. Next, measure the distance from the front axle center point to each tip of the rear axle. Distances must be exactly the same. Secure the rear axle to the floor. This alignment ensures that the centerline of the racer is parallel to the direction of travel and the car is balanced side to side.

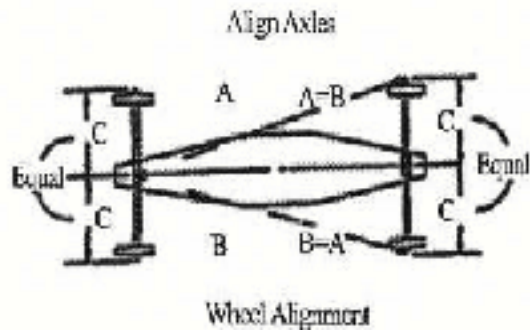

Reminder: Nose to Rear Axle - 70" Maximum (Figure B)

Balancing/Weight:

An important factor in soapbox racer design is the weight distribution. A well-balanced car will roll cleaner downhill and will be more stable in handling and braking. The more weight over a wheel, the more resistance it presents. For this reason alone, you will want to have even weight distribution over all four wheels.

An unbalanced car may tend to wander. In a car in which more weight is positioned towards the rear, the light front end will steer sluggishly. This leads to erratic motion. Also, a light front end tends to bounce more when hitting bumps. If the front end is too heavy, the car will tend to fishtail easily and rear mounted brakes will be less effective.

Any weight added to the car must be securely fastened to the floorboard and must not interfere with steering or braking. Any weight added during the event requires inspection and approval. Any unauthorized weight addition will disqualify the vehicle.

Body:

Safety must be given priority with regards to building and racing the cars. Mishaps do occur, and it is your responsibility to design and build a car that is safe and presents minimal danger to the driver and spectators in the event of an accident. Keep in mind that the shape of the front of the car can present a serious hazard in a collision, as these cars can reach speeds in excess of 35 mph (60 km/h). Sharp pointed designs are to be avoided.

Having the front wheels visible from the driver's position would be an asset.

Two-Person Cars:

- The two-person cars allow others a chance to experience the soap box sensation. This class will allow a special needs 'rider' to be chauffeured down the hill by a parent, guardian, or other competent 'driver'.
- Because of the additional weight alone, we adhere to strict safety requirements, in addition to the general building instructions.
- All cars will be required to fit within the dimension parameters, as outlined previously. This is necessary, so that the vehicles fit on the start ramps.
- Two 'adult size' people will not fit in a car, within the current building guidelines.
- To provide assistance, if required, we will need to know a little about the 'rider', or special needs individual, and the 'driver', as the car is being built.
- The driver should be at least of comparable size and weight to the rider (ie a 160 lb rider cannot be driven by a 110 lb driver).
- As noted in the 'Building Rules & Regulations', the driver will be required to prove proficiency in the operation of the car, with the rider present.

All rules for construction, plus the additional requirements below, are to be followed.

GENERAL:

- Floorboard will be a minimum of 3/4" plywood, or equivalent.
- In any location where eyebolts are to be used, they must be a minimum 1/4" closed.
- All locations where cable clamping is required must be DOUBLE clamped.
- A full-face helmet for the 'rider' is strongly recommended.
- In addition to seat belts, adjustable shoulder restraints for the 'rider' are mandatory.
- A removable roll bar for the 'rider' is recommended.
- Adjustable seats are recommended.

STEERING:

- The steering will be a cable controlled, vertical shaft (supported), or direct linkage and "bell-crank".
- No 'kingpin' style steering will be used.
- Steering cable will be directed through closed pulleys, rather than eyebolts.

BRAKES:

- A plunger type, center mount location is strongly recommended.
- The contact surface (supported) will be a minimum 6"x6" reinforced rubber pad (ie car tire, conveyor belt).

AXLES:

- Wood axle trees are recommended, with a minimum finished depth of 1-1/4" above the axle rod. Other construction methods will be assessed individually.
- The intent is to remove any flex and/or deflection in the axle rod.

Class M Modified:

- **Drivers:** Minimum 8 years of age
- **Dimension:** Maximum 70" – Nose to Center of Rear Axle (See Page 3)
- **Wheels:** Maximum 12" diameter, solid double disc metal, solid rubber.
Or, approved (stamped) composite soap box wheels.
- **Body** materials, other than wood, will be carefully examined.
- **Steering & Brake Requirements**, as per the general building instructions.
- Akron-Type Kit Cars may run in this class, provided they meet the dimension requirements, as per Page 3.
- If aluminum or other metal body panels are used, all edges must either be rolled or beaded (no sharp body edges).
- Modified/Experimental (M / XP) variances will require prior approval.

CLASSES:

- **Class 'A':** **Ages 8-11**
- **Class 'B':** **Ages 12-14**
- **Class 'C' (Corporate 10) - Max 10" Wheels:** **Any age driver, 8 or over**
- **Class 'D' (Corporate 12) - Max 12" Wheels:** **Any age driver, 8 or over**
- **Class 'M' Modified Class:** **Any age driver, 8 or over**
- **Class 'E' Special Needs:** **Entry by specific request & approval**

Carefully re-read all sections of the manual. Make a copy of the following checklist and use it during testing to help you pass the Safety Inspection easily.

SAFETY AND SPECIFICATION CHECKLIST

The following conditions are to be adhered to. Remember, only the Safety Inspection Committee can concession non-compliances.

Structural Safety:

- All 'MANDATORY CAR DIMENSIONS' must be met.
- All steering and brake system turnbuckles prevented from turning due to vibration.
- All parts of 'Major Components' are mounted securely with through bolts, suitable flat washers and lock nuts, lock washers or 'Lock-tite'. Use 'closed' eye bolts.
- All steering and brake system cables remain snug throughout movement extremes.
- All cables (1/8" min. aircraft) are terminated with clamps. ('Double' clamps-Optional)
- No open pulleys are used (where cable may come off the pulley wheel).
- Brake pads that drag on the ground are able to extend 1" below the road surface.
- Wheels and front axle king pin are secured with locking nuts, double nuts, cotter pins, or other suitable method.
- Wheels do not bind or rub anywhere throughout movement extremes.
- Axles are securely fastened.
- No sharp objects are in the vicinity of the driver when seated.
- All parts of the 'Major Components' are accessible for visual inspection.
- Car is reasonably solid in construction and free of loose parts.
- Braking system design is mechanically sound and effective.
- Steering system design is mechanically sound and effective.
- Steering wheel design does not present a potential hazard.
- Steering stops are adequately positioned and secured.
- Seat belts are installed and properly adjusted.
- Roll bar (if used) is structurally sound and effective.
- Helmet is present and fits.
- Goggles (if used), do not fog up.

Driver Proficiency:

- Driver can operate brakes satisfactorily.
- Driver can operate steering satisfactorily.
- Driver understands the structure of the race regarding:
 - when to brake / how to brake safely
 - staying in own lane
 - false start procedures
- **REMINDER: Driver changes, within 48 hours of the event, must receive prior approval of the organizers.**

INSPECTIONS

ALL cars must pass a formal inspection with their drivers prior to race Day. You will be provided with the place, dates and times for the inspections. Two inspection dates are usually held and you are encouraged to attend the first inspection, even if your car is far from being completed. This will allow you to identify potential problems before you develop them too far. When changes are indicated, the car must be re-inspected to assure total compliance. **The Safety Inspection Committee is the only body permitted to approve non-compliances and their decision is final.**

- Car must pass final inspection **prior to race day**. All mechanical components of the car will be inspected for structural, design and safety adequacy.
- Driver(s) must pass final inspection **prior to race day**. The driver(s) will be checked for driving and braking ability, fit in regards to roll bar and seat belts, and adequate protective wear. Inspection sticker will not be issued without driver inspection.
- No revisions to the car are permitted after the final inspection.
- Due to time restraints, **no car will be given a final inspection on race day**.
- Throughout the weekend, any major repairs will require a new inspection.

Only after the racer passes all of the above requirements will it be allowed on the race hill. Reasonable efforts will be made by the committee to have your car qualify; but **SAFETY IS THE UTMOST PRIORITY!**

QUESTIONS, please CONTACT: 625-6050 or macomuzzi@georgejeffrey.com

Or one of the gentlemen listed below

Dennis Niittynen

Phone: 807-767-2647

E-mail: melbel@tbaytel.net

Doug Lund

Phone: 807-577-4191

E-mail: dougclund@gmail.com

Progress inspections can be arranged by contacting macomuzzi@georgejeffrey.com

RACING RULES AND REGULATIONS

**ALL DRIVERS & CREW MUST ATTEND DRIVERS' MEETING
ALL CARS MUST HAVE A CREW MEMBER AT THE STAGING AREA
TO HELP DRIVER & STAGE CAR
(1 @ BOTTOM & 1 @ TOP OF HILL)**

Set-Up:

- Elimination Match Races

Multiple Drivers:

- A car may only be registered ONCE in a class.
- Therefore, multiple drivers in the SAME age group, SAME car, must share driving.

Radios:

- No two-way radios allowed in cars, as it interferes with race communications.

Re-Races:

Re-races will be considered for the following reasons:

1. Interference from spectators, obstacles or other cars entering your lane, etc.
2. Malfunction of timer system.
3. A false start as deemed by the starting officials.
4. An emergency stoppage of the race.

Re-races will not be considered for the following reasons:

1. Mechanical breakdown of own car.
2. Inadvertent or intentional braking (not due to interference).
3. Car leaving own lane (not caused by interference).
4. Car striking cones, barriers (not caused by interference).
5. Weather conditions.
6. General track conditions (manhole covers, surface conditions, etc).

In all cases, re-races will be determined by consensus of the committee and may be denied for such reasons as time restrictions, etc.

Braking At Finish Line:

1. Brakes must be applied as soon as possible after the car has crossed the finish line.
2. Cars must stop in a STRAIGHT LINE without fishtailing or spinning.
3. 'Barriers' are NOT to be deliberately hit.
4. **If braking is deemed by finish line officials to be inadequate or unsafe, the car will not be allowed to race until all appropriate adjustments to car or driver have been made.**

Repairs:

An attempt will be made to allow repairs between heats ONLY.

Questions and Concerns:

During the event, questions and concerns will be addressed by the Race Director.

Decisions regarding controversial matters will be made by consensus of the Official Race Committee. The Official Race Committee may elect to reserve final decisions until after race day.

Official Race Committee Members will be introduced at the Drivers' Meeting.

UNDER NO CIRCUMSTANCES are the scoring officials, at the top and bottom of the hill, to be approached by drivers or drivers' representatives to discuss results or race line-up.